

Bladder Accumulators

Standard

1. DESCRIPTION

1.1. FUNCTION

Fluids are practically incompressible and cannot therefore store pressure energy.

The compressibility of a gas is utilised in hydro-pneumatic accumulators for storing fluids. HYDAC bladder accumulators are based on this principle, using nitrogen as the compressible medium.

The bladder accumulator consists of a fluid section and a gas section with the bladder acting as a gas-proof screen. The fluid around the bladder is connected with the hydraulic circuit, so that the bladder accumulator draws in fluid when pressure increases and the gas is compressed. When the pressure drops, the compressed gas expands and forces the stored fluid into the circuit.

HYDAC bladder accumulators can be used in a wide variety of applications, some of which are listed below:

- energy storage
 - emergency operation
 - force equilibrium
 - leakage compensation
 - volume compensation
 - shock absorption
 - vehicle suspension
 - pulsation damping
- (see brochure on Hydraulic Dampers no. 3.701../..)



1.2. CONSTRUCTION

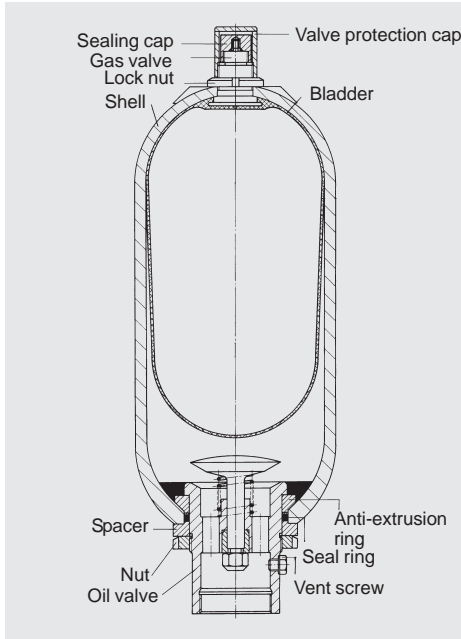

1.2.1 Construction

● Standard bladder accumulators SB330/400/500/550

HYDAC standard bladder accumulators consist of the pressure vessel, the flexible bladder with gas valve and the hydraulic connection with check valve. The pressure vessel is seamless and manufactured from high tensile steel.

● Bladder accumulator SB330N

The flow optimised design of the standard oil valve enables the maximum possible operating fluid flow rate to increase to 25 l/s on this accumulator type.

● High Flow bladder accumulator SB330H

HYDAC high flow bladder accumulators, type SB330H, are high performance accumulators with a flow rate of up to 30 l/s. The fluid connection is enlarged to allow higher flow rates.

1.2.2 Bladder materials

The following elastomers are available as standard:

- NBR (acrylonitrile butadiene rubber, Perbunan),
- IIR (butyl rubber),
- FKM (fluoro rubber, Viton®),
- ECO (ethylene oxide epichlorohydrin rubber).

The material used depends on the respective operating medium and temperature.

1.2.3 Corrosion protection

For use with chemically aggressive media the accumulator shell can be supplied with corrosion protection, such as plastic coating on the inside or chemical nickel plating.

If this is insufficient, then stainless steel accumulators must be used.

1.3. MOUNTING POSITION

HYDAC bladder accumulators can be installed vertically, horizontally and at a slant.

When installing vertically or at a slant, the oil valve must be at the bottom. On certain applications listed below, particular positions are preferable:

- energy storage: vertical
 - pulsation damping: any position from horizontal to vertical
 - maintaining constant pressure: any position from horizontal to vertical
 - volume compensation: vertical
- If the mounting position is horizontal or at a slant the effective volume and the maximum permissible fluid flow rate are reduced.

1.4. TYPE OF MOUNTING

- By using an appropriate adaptor, HYDAC accumulators, up to size 1 l, can be mounted directly inline
- For strong vibrations and volumes above 1 l, we recommend the use of HYDAC accumulator supports or the HYDAC accumulator mounting set. (Brochure "Supports for Hydraulic Accumulators" no. 3.502. and ACCUSET SB, no. 3.503.)

2. TECHNICAL SPECIFICATIONS

2.1. EXPLANATORY NOTES

2.1.1 Working pressure

see tables
(In some countries this can differ from the nominal pressure)

2.1.2 Nominal volume

see tables

2.1.3 Effective gas volume

see tables,
based on nominal dimensions; this differs slightly from the nominal volume and must be used when calculating the effective volume.

2.1.4 Effective volume

The fluid volume available between the working pressures p_2 and p_1 .

2.1.5 Max. pressure fluid flow rate

In order to achieve the max. flow rate given in the tables, the accumulator must be mounted vertically. It has to be taken into account that a residual fluid volume of approx. 10% of the effective gas volume remains in the accumulator.

2.1.6 Fluids

The various seal and bladder materials are compatible with the following fluids:

Material	Fluid
NBR LOW TEMP NBR	Mineral oils (HL, HLP, HFA, HFB, HFC), water
ECO	Mineral oil
IIR	Phosphate ester
FKM	Chlorinated hydrocarbons, petrol

2.1.7 Permissible operating temperature

The permissible operating temperatures are dependent on the application limits of the metallic materials and the bladders.

The standard valve bodies, gas valves and accumulator shells are suitable for temperatures -10 °C to +80 °C.

Outside these temperatures, special material combinations must be used. The following table shows the correlation between bladder material and application temperature.

Material	Temperature ranges
NBR	- 15 °C to + 80 °C
LOW TEMP NBR	- 50 °C to + 80 °C
ECO	- 30 °C to + 120 °C
FKM	- 10 °C to + 150 °C

2.1.8 Gas charging

Always charge with 99.995% nitrogen only, filtered to < 3 µm.

If other gases are to be used, please contact HYDAC for advice.

NEVER USE OXYGEN OR COMPRESSED AIR.

RISK OF EXPLOSION.

2.1.9 Critical values for gas pre-charge pressure

$$p_0 \leq 0.9 \times p_1$$

with a permissible pressure ratio of: $p_2 : p_0 \leq 4:1$

p_2 = max. operating pressure
 p_0 = gas pre-charge pressure

2.1.10 Certificate codes

Australia	F*
Brazil	U***
Canada	S1**
China	A9
CIS	A6
EU member states	U***
Hungary	U***
India	U***
Japan	P
New Zealand	T
Poland	A4
Romania	U
Slovakia	A8
South Africa	U***
Switzerland	U
USA	S

others on request

- * = approval required in the individual territories
- ** = approval required in the individual provinces
- *** = alternative certificates possible

On no account must any welding, soldering or mechanical work be carried out on the accumulator shell. After the hydraulic line has been connected it must be completely vented. Work on systems with accumulators (repairs, connecting pressure gauges etc) must only be carried out once the pressure and fluid have been released.

Please observe operating instructions!

Note:

Application examples, accumulator sizing and extracts from approvals regulations on hydraulic accumulators can be found in the accumulator overview brochure no. 3.000../...

2.2. MODEL CODE

(also order example)

SB 330 H - 32 A 1 / 112 U - 330 A

Series

Type

- H = High Flow
 - N = increased flow, standard oil valve dimensions
 - A = shock absorber
 - P = pulsation damper
 - S = suction flow stabiliser
 - B = bladder top-repairable
- Combinations possible: e.g.
 HB = High Flow with a top-repairable bladder or
 PH = pulsation damper with high flow rate.
 No details = standard

Nominal volume in l

Fluid connection

- A = standard connection, thread with internal seal face
- F = flange connection
- C = valve mounting with screws on underside
- E = sealing surfaces on the front interface (e.g. on thread M50 x 1.5)
- G = male thread
- S = special connection according to customer specification

Gas side

- 1 = standard model ⁴⁾
- 2 = back-up model
- 3 = gas valve 7/8-14UNF with M8 female thread
- 4 = 5/8" gas valve
- 5 = gas valve M50 x 1.5 in accumulators smaller than 50 l
- 6 = 7/8-14UNF gas valve
- 7 = M28 x 1.5 gas valve
- 8 = M16 x 1.5 gas valve
- 9 = special gas valve according to customer specification

Material code ¹⁾

- 112 = standard for mineral oil depending on operating medium
- others on request

Fluid connection

- 1 = carbon steel
- 2 = high-strength steel
- 3 = stainless steel (Niro) ³⁾
- 6 = low temperature steel

Accumulator shell

- 0 = plastic coated (internally)
- 1 = carbon steel
- 2 = chemically nickel plated (internally)
- 4 = stainless steel (Niro) ³⁾
- 6 = low temperature steel

Accumulator bladder ²⁾

- 2 = NBR
- 3 = ECO
- 4 = IIR (Butyl)
- 5 = TT-NBR (low temperature)
- 6 = FPM
- 7 = others

Certificate code

- U = PED 97/23/EC

Permissible operating pressure (bar)

Connection

- Thread, codes for fluid connections: A, C, E, G
- A = thread to ISO 228 (BSP)
- B = thread to DIN 13 or ISO 965/1 (metric)
- C = thread to ANSI B1.1 (UN.-2B seal to SAE J 514)
- D = thread to ANSI B1.20.1 (NPT)
- S = special thread according to customer specification

Flange, codes for fluid connection: F

- A = DIN flange
- B = flange ANSI B 16.5
- C = SAE flange 3000 psi
- D = SAE flange 6000 psi
- S = special flange according to customer specification

Required gas pre-charge pressure must be stated separately!

- 1) Not all combinations are possible.
- 2) When ordering spare bladders, please state bladder connection port size.
- 3) Depending on type and pressure rating.
- 4) Gas valve type in SB < 50 l = 7/8 - 14 UNF, in SB ≥ 50 l = M50 x 1.5

3. DIMENSIONS AND SPARE PARTS

3.1. DIMENSIONS

Nominal volume Litres	Valve	max. working pressure (PED 97/23/EC) bar	Eff. gas volume litres	Weight kg	A	B	C	Ø D	J	Ø E	SW	Q ¹⁾	
					mm	mm	mm	max. mm	thread ISO 228	mm	mm	l/s	
0.5	standard	400	0.5	2.8	270	57	33.5	95.5	G 3/4	50	32	4	
1		330	1.0	4.5	302	68	58	118	G 1	67	50		45
		550		8.5	334			121				G 1 1/4	
2.5		330	2.4	10	532	63	58	118	G 1	67	50	45	4
		550	2.5	13.5	539	68	58	121	G 1 1/4	67	50	45	4
4		330	3.7	11.5	410	63	58	173	G 1 1/4	67	50	45	4
		400		15.5	410	63	172	G 1 1/4					
5		550	4.9	23	867	68	58	121	G 1	67	50	45	4
6		330	5.7	15	540	63	58	173	G 1 1/4	67	50	45	4
10 ²⁾		330	9.3	25	728		58		G 1 1/4	67	50	45	4
10	standard	330	9.3	31.5	568	103	58	229	G 2	100	70	15	
	N			25									
	H		9	34.5	603	138	58	229	G 2 1/2	125	90	30	
	standard		400	9.3	37.5	572	103	68	233	G 2	100	70	15
13	standard	330	12	43	660	103	58	229	G 2	100	70	15	
	N			25									
	H		46	695	138	58	233	G 2 1/2	125	90	30		
	standard		400	49	666	103	68	233	G 2	100	70	15	
20	standard	330	18.4	50.5	896	103	58	229	G 2	100	70	15	
	N			25									
	H		17.5	53.5	931	138	58	229	G 2 1/2	125	90	30	
	standard		400	18.4	63.5	896	103	68	233	G 2	100	70	15
24	standard	330	23.6	69.0	1062	103	79	229	G 2	100	70	15	
	N			25									
	H		24	72	1097	138	79	229	G 2 1/2	125	90	30	
	standard		400	33.9	87	1411	103	79	229	G 2	100	70	15
32	standard	330	33.9	87	1411	103	79	229	G 2	100	70	15	
	N			25									
	H		32.5	90	1446	138	79	229	G 2 1/2	125	90	30	
	standard		400	33.9	104.5	1411	103	68	233	G 2	100	70	15
50	standard	330	47.5	117.5	1931	103	68	229	G 2	100	70	15	
	N			25									
	H		120.5	1966	138	68	229	G 2 1/2	125	90	30		
	standard		400	142	1931	103	68	233	G 2	100	70	15	
60	standard	330	48.3	169	1951	77	68	241	G 2	100	75	15	
			60	182	1156	138	68	356	G 2 1/2	125	90	30	
			80	221	1406								
			100	255	1656								
			130	305	1976								
			160	396	2006								
200	485	2306											

Dimensions

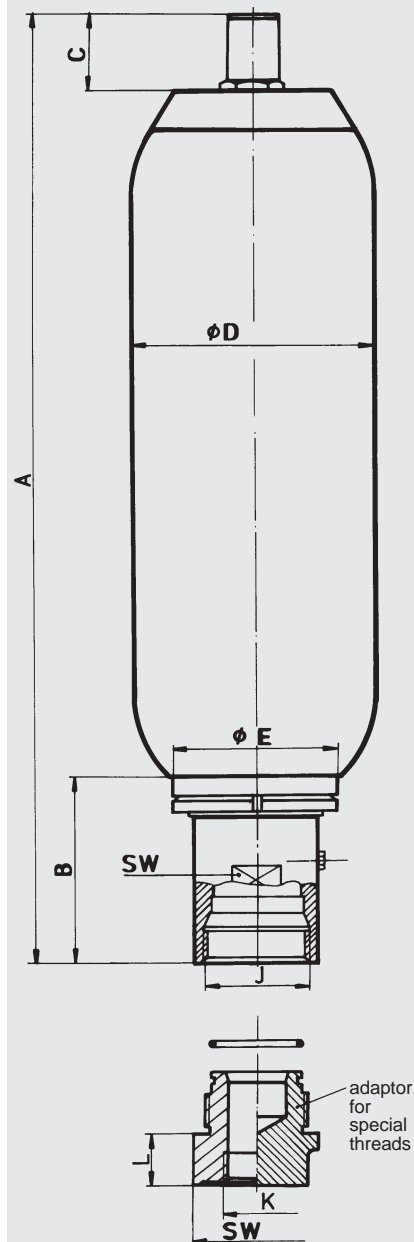

3.2. ADAPTORS¹⁾

Series	Nominal volume litres	J ISO 228	K ISO 228	L mm	SW mm
SB330/40 SB330 N	0.6 - 1	G 3/4	G 3/8	27	32
	2.5 - 10 ¹⁾	G 1 1/4	G 3/4	13	46
	10 ²⁾ - 50	G 2	G 1 1/2	36	65
SB550	1 - 5	G 1	G 3/4	31	46
SB330	60 - 200	G 2 1/2	G 2	40	100
SB330 H	10 - 50	G 2 1/2			

1) order separately

2) 10 l standard model

*) slimline version for confined spaces

3.3. SPARE PARTS

SB 330/400/440/500/550
SB 330 H / SB 330 N

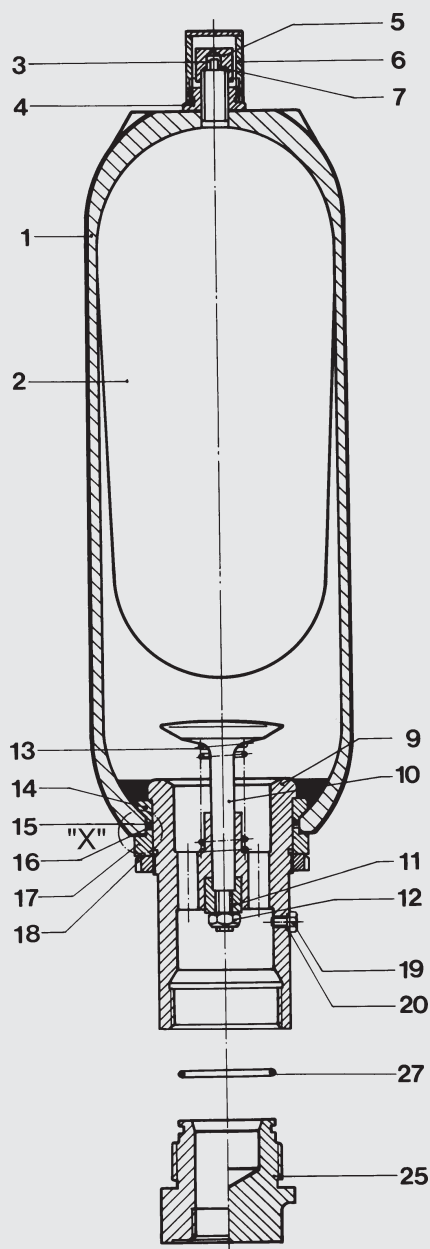

Detail "X"

SB 330/400 – 0.5 to 6 l

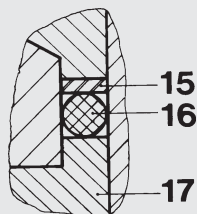

SB 330/400/500 – 10 to 200 l and
SB 330 H-10 to 200 l
SB 550-1 to 5 l

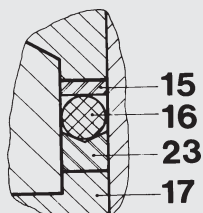

Description	Item
Anti-extrusion ring	14
Oil valve complete, consisting of:	
Oil valve body	9
Valve	10
Damping sleeve	11
Safety nut	12
Valve spring	13
Anti-extrusion ring	14
Protection ring	15
O-ring (see above)	16
Spacer	17
Lock nut	18
Vent screw	19
Seal ring	20
Back-up ring	23
Seal kit *	
consisting of:	
O-ring (see above)	7
Protection ring	15
O-ring (see above)	16
Seal ring	20
Back-up ring	23
O-ring (see above)	27

Description	Item
Gas valve insert *	3
Repair kit * ²⁾	
consisting of:	
Bladder	2
Gas valve insert	3
Lock nut	4
Cap nut	5
Valve protection cap	6
O-ring 7.5 x 2.0 ¹⁾	7
Protection ring	15
O-ring	16
Seal ring	20
Back-up ring	23
O-ring	27

* Recommended spare parts

¹⁾ For code 663 and 665
different dimensions.

²⁾ When ordering please state smallest
bladder connection port size.
Item 1 not available as spare part,
Item 25 has to be ordered separately
(see page 4)

3.4 REPAIR KITS

NBR, carbon steel
Nom. volume: 0.5 to 200 litres
Standard gas valve

Nom. volume [L]	Stock no.
1	02106261
2.5	02106200
4	02106204
5	02106208
6	02112100
10 *	03117512
10	02106212
13	02106216
20	02106220
24	02106224
32	02106228
50	02106252
60	03117513
80	03117514
100	03117515
130	03117516
160	03117517
200	03117558

*) slimline version for confined spaces
others on request

4. BLADDER ACCUMULATORS BACK-UP TYPE SB 330-...A2

4.1. CONSTRUCTION

Based on the bladder accumulators 20 - 50 l, the gas side of these accumulators is designed especially for connecting to nitrogen bottles.

A perforated anti-extrusion rod prevents damage to the bladder when the accumulator is charged.

This construction can also be used for the separation of fluids (taking into account the volume ratios valid for bladder accumulators).

4.2. DIMENSIONS

Nom. volume litres	Effect. gas volume litres	Weight kg	A max. mm
20	17.5	53.5	905
24	24	72	1070
32	32.5	89	1420
50	47.5	119.5	1930

4.3. SPARE PARTS

Description	Item
Repair kit *	
consisting of:	
Bladder	2
Lock nut	4
O-ring 7.5 x 2.0 ¹⁾	7
Protection ring	15
O-ring 80 x 5 ¹⁾	16
Seal ring	20
Back-up ring	23
O-ring 48 x 3 ¹⁾	27
O-ring 22 x 2.5 ¹⁾	31
O-ring 11 x 2 ¹⁾	33
Anti-extrusion ring	14
Rod	30

* Recommended spares

¹⁾ For code 663 and 665 different dimensions.

Item 1 not available as spare part.

Item 25 to be ordered separately (see page 4).

Item 32 type 1 Standard.

Other spare parts – see point 3.

4.4 REPAIR KITS

Designation	Stock no.
SB330/400A2-20 NBR	03119500
SB330/400A2-24 NBR	03119502
SB330/400A2-32 NBR	03119498
SB330/400A2-52 NBR	03119499

others on request

Type 1

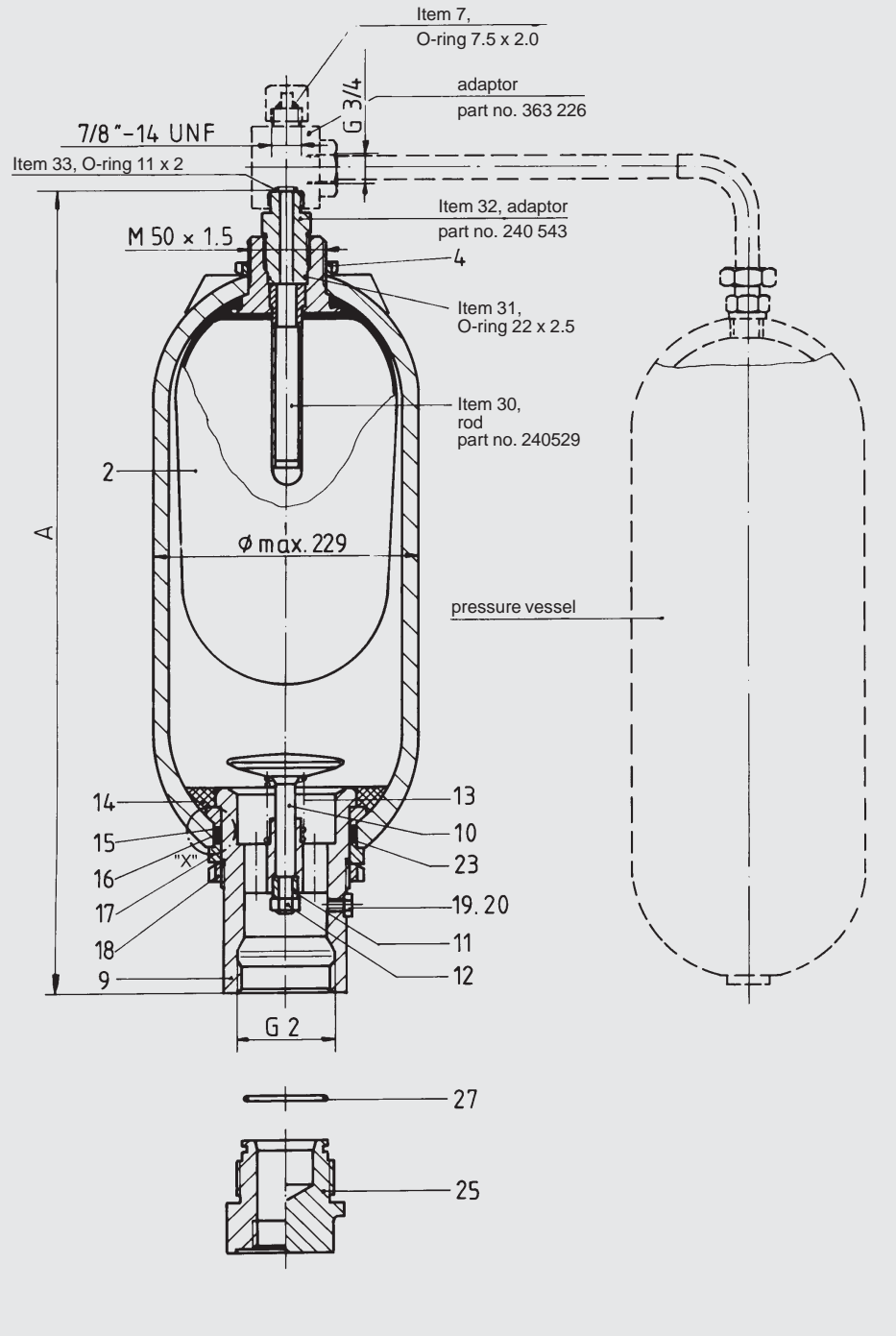

Type 2

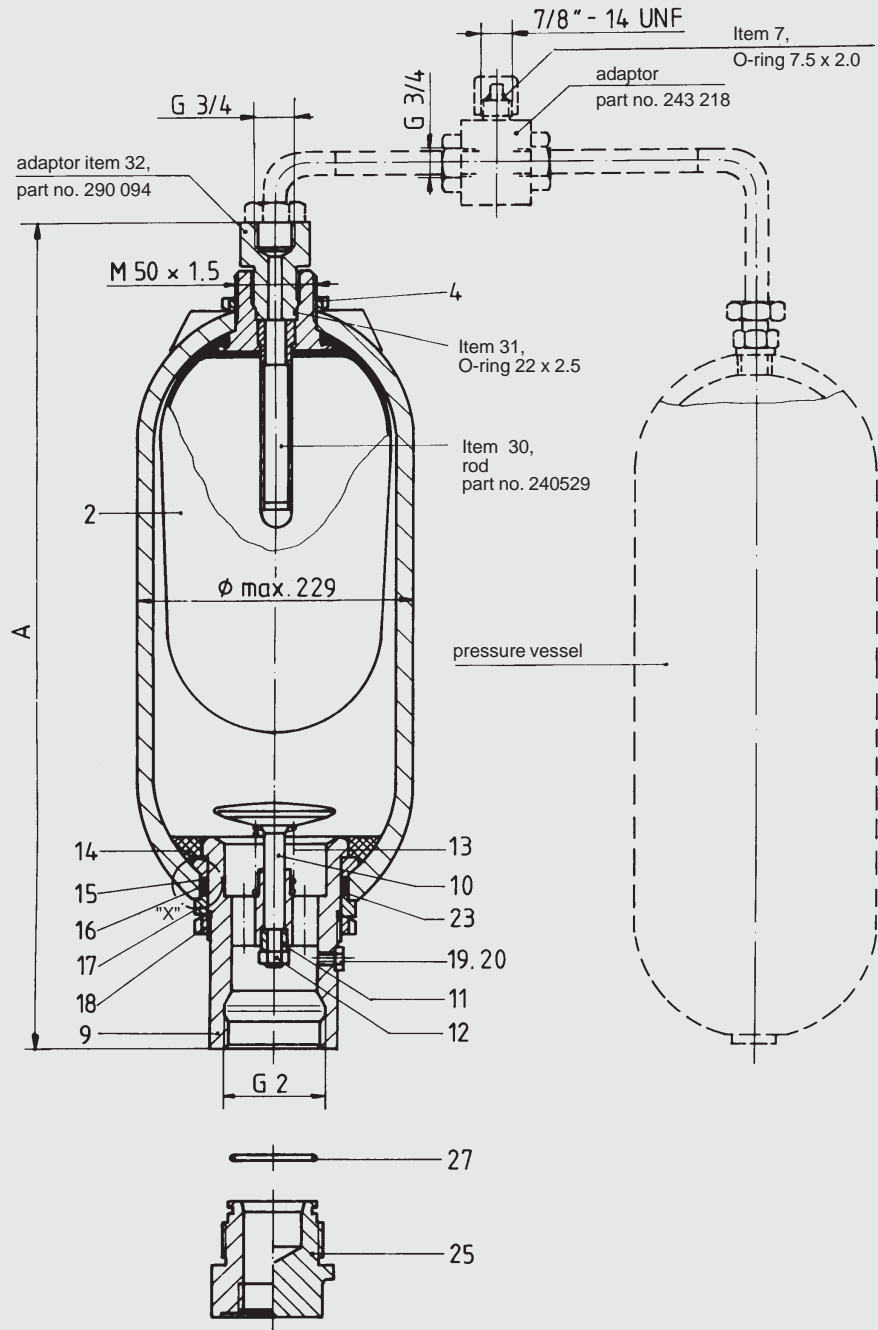

5. NOTE

The information in this brochure relates to the operating conditions and applications described.

For applications or operating conditions not described, please contact the relevant technical department.

Subject to technical modifications.